



INSTALLATION GUIDELINES

Now that you own a Fortem Engineered Waterproof Floor you can make sure it is installed correctly by following these installation guidelines to the letter. Here you'll find the more important things to do before, during, and after installation. These instructions are good for our **GRAND SUITE Collection** of Engineered Waterproof Floors.

INTRODUCTION

Our floors are designed to be installed as floating floors, meaning that they are not fixed to the subfloor in any way. But they can also be glued directly to the subfloor. The method you select to install your floor depends upon the conditions of the area. **IMPORTANT:** No matter what method you choose, it's important to prepare the subfloor prior to installation.

Make sure that the subfloor is dry, flat, stable, clean and free from debris, grease and chemical substances. If needed, scrape off and clean up old adhesives. Prior to installation, carefully remove all debris, sweep and vacuum. Repair surface imperfections and cracks. We recommend removing existing baseboards and installing new moldings after installation of FORTEM Engineered Waterproof Floors is complete.

GENERAL GUIDELINES

- Cartons must be transported and stored horizontally, and in neat stacks at all times. Storing them vertically can damage the click mechanism or warp the planks.
- Fortem Waterproof Floors should only be installed indoors, **NEVER** outdoors.
- Make sure the subfloor is flat. Any unevenness of 1/8" over 6 feet should be patched.
- Remove all bumps, and repair any cracks or holes on the concrete slab.
- Sand any lippage between plywood sheets. Remove visible nails or staples.
- Test for subfloor moisture before you install. While these floors are 100% waterproof, they are designed for day-to-day use in dry and proper conditions.
- Examine planks for any damage before installation.
- Make sure to arrange planks to ensure uniform distribution of tone and graining.
- For an ideal effect, install the planks along the longest wall of the overall space, and/or parallel to the light source in the room. Be sure to consider hallways and other narrow areas. A dry mockup layout can be a good idea prior to installation.
- Ensure that the end joints of the planks are staggered by at least 8 inches.
- Measure the room before you start installing underlayment or flooring planks. Make sure that the last row of panels is at least 3 inches wide when finishing the installation. For optimal results plan for the first and last row are the same width.
- A chalk line can help ensure the installed planks are aligned.
- Cut our Engineered Waterproof Floor planks using a utility knife with the decor side facing up. After scoring it with the knife, snap both sides pushing downwards.
- Make sure to leave an expansion gap of 1/4" (6 mm) around the perimeter of the room.

RECOMMENDED TOOLS

- Tape Measure.
- T-Square and Straight Edge.
- Pencil, marker or chalk.
- 3M Scotch Blue 2080 Tape or similar.
- 1/4" Spacers for the perimeter.
- Pull bar and Hand saw.
- Closed-cell Dense WPC Underlayment. ECLIPSE II padding is recommended.
- Miter or Table Saw (A utility knife can be used to cut the planks both width and lengthwise, but a power saw will speed up installation time, and result in cleaner cuts overall)

PRIOR TO INSTALLATION

Most problems with flooring installations are the result of poorly prepared subfloors. Uneven or rough subfloors will create problems that will transfer to the floor. FORTEM Engineered Waterproof Floors are approved for the following subfloors: Concrete, Wood and certain existing floors. Prior to installation of any flooring, the installer must ensure that the jobsite and subfloor meet the requirements of these instructions. FORTEM is not responsible for flooring failure resulting from unsatisfactory job site and/or subfloor conditions. Please follow the specific preparation instructions for your subfloor.

While FORTEM GRAND SUITE Collection is completely waterproof, it is not a moisture barrier. It's still a good idea to make sure concrete is cured and tested for moisture prior to installation. A moisture barrier should be placed in the crawl space and under FORTEM Engineered Waterproof Floors when installing over a concrete subfloor. NOTE: Most foam underlayments already come with moisture barrier properties. (Be sure to follow your underlayment installation guidelines for your specific type of floor)

Moisture won't damage FORTEM Engineered Waterproof Floors, but it can get in the walls and structure of the home. A couple of extra dollars and a few minutes is a small investment for the added protection and peace of mind. Because houses and buildings, as well as adjacent hardwood or laminate floors, expand and contract, we recommend leaving a 1/4" expansion gap between FORTEM Engineered Waterproof Floors and perimeter walls or adjacent floors.

SUBFLOOR REQUIREMENTS

Concrete: FORTEM Engineered Waterproof Floors may be installed over on-grade, above-grade or below-grade concrete subfloors.

- Concrete floors shall be constructed in accordance with the American Concrete Institute (ACI) 302.1 Guide for Concrete Floor and Slab Construction.
- Concrete shall be finished and cured according to ACI and have a minimum compressive strength of 3500 psi. Installation of a moisture vapor barrier is recommended prior to the pouring of on or below grade slabs.
- Moisture vapor transmission should not exceed 3 lbs / 1000 sq ft over 24 hours per ASTM F-1869 (Anhydrous Calcium Chloride Test). Moisture may also be tested according to ASTM F-2170 (Standard Test Method for Determining Relative Humidity in Concrete Floor Slabs Using Probes). When tested according to this method, the internal relative humidity shall not exceed 75%.
- Concrete subfloors must be hard, dense, and free from powder or flaking. New concrete slabs must be thoroughly dry (at least six weeks) and completely cured. The final responsibility for determining if the concrete is dry enough for installation of the flooring lies with the floor covering installer.
- Holes, grooves, expansion joints, and other depressions must be filled with a Portland Cement based underlayment, troweled smooth, and feathered evenly with the surrounding surface.
- FORTEM GRAND SUITE Engineered Waterproof Floors can be installed over radiant heat concrete subfloors if a constant room and floor temperature of 65°F (18°C) can be maintained during acclimation, installation, and for 48 hours after installation is complete. For health and safety reasons, a maximum floor surface temperature of 82°F (27°C) must be maintained.
- Turn off radiant floor heating 24 hours before and after installation. Separate rooms with and without radiant floor heating or rooms with different temperature controllers using our SlimTrim transition profile.
- Electric heating mats that are not embedded into the subfloor are not recommended for use underneath FORTEM Engineered Waterproof Floors. Using electric heating mats that are not embedded and applied directly underneath FORTEM Engineered Waterproof Floors could void the warranty for your floor in case of failure. It is best to install FORTEM Engineered Waterproof Floors over embedded radiant floor heating systems and adhere to the guidelines listed above.

Wood: FORTEM Engineered Waterproof Floors can go over virtually any sound wood-underlayment or subfloor. Always fasten underlayment in accordance with the manufacturer's recommendations, to avoid squeaking and movement. Ensure the wood subfloor is flat, free of lippage between plywood sheets, dry and sound. Remove or hammer-down any exposed nail or staple prior to installation.

Existing Floors: FORTEM Engineered Waterproof Floors can be installed over a variety of finished floors including single layer resilient sheet floor and tile, ceramic, marble and terrazzo. The surface must be in good condition and show no signs of excessive moisture conditions. Do not install flooring over heavily cushioned floors such as rubber or cork, or over tile installed over concrete below grade level. The grout joints in ceramic tile and marble must be leveled so they are flush with the tile surface. Additionally, the tile may require several skim coats to achieve a flat surface.

IMPORTANT: Thoroughly sweep, vacuum and remove any dust and debris from the subfloor. Once the subfloor is in proper condition lay the flooring underlayment as per the manufacturer guidelines. ALWAYS install the underlayment with the moisture barrier film facing downwards.

INSTALLATION INSTRUCTIONS

For best appearance, planks should be installed along the longest dimension of the room (more importantly the whole house or office space) and preferably parallel with outside light sources (i.e. windows and doors). Consider hallways and other narrow spaces before deciding in which direction to install the planks.

IMPORTANT

Open multiple boxes prior to start installing planks to ensure an even distribution of the color and grain variation. Avoid installing two identical or similar planks next to each other to achieve a professional look.

PRO-TIP

For best appearance, measure the entire width of the room and calculate the measurement so that the first and last row of planks are exactly the same width. Remember to consider a 1/4" gap on each end of the room.

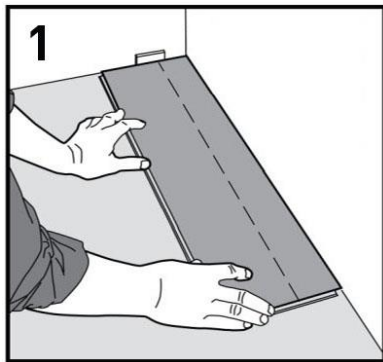

1. Start the first row. Cut each of the planks length-wise with the previously calculated measure. (Don't worry if the plastic insert falls off the groove. You can easily place it back). Trim off the tongue on the short side of the first plank.

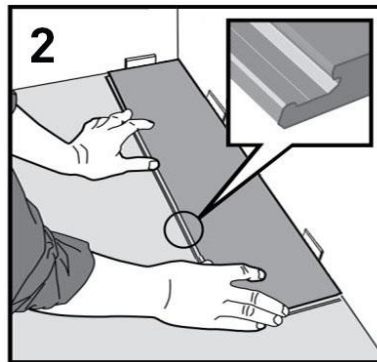

2. Begin placing the planks for the first row at the left-hand corner of the room. Place the first plank with the two cut sides facing the wall. The groove should face outwards in both directions (see image above). Remember to use 1/4" spacers around the perimeter.

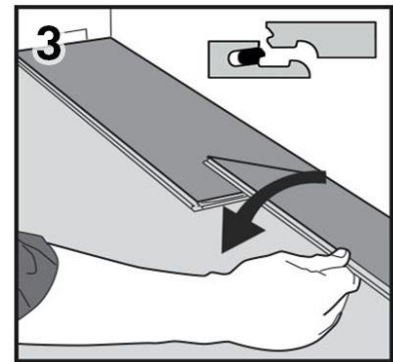

3. Put the second plank by pushing the tongue against the groove of the first plank. Use pressure on the short edge until you hear a snap or click. Continue doing the same with the rest of the planks of the first row. Cut the last plank to finish the row.

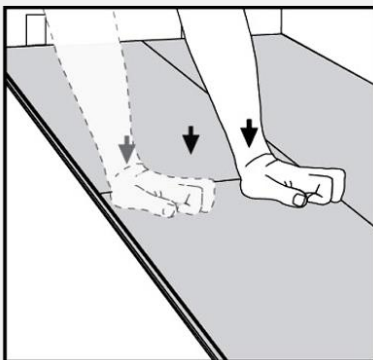

IMPORTANT

If you are using a tapping block or rubber mallet, do not use excessive force when locking the planks together. You can easily do this by pushing firmly with your hands over the joint of two planks.

For video instructions on how to properly install these floors please visit www.fortem.us/installation

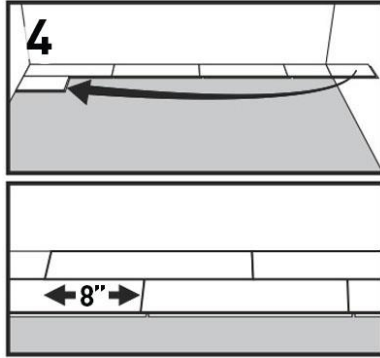

4. To start the second row, use 1/4 or 1/3 of a full-width plank (You can use the left-over piece from the last plank of the first row). Ensure that the end joints of the planks from the second row and the first row are staggered by at least 8 inches. With the cut side against the wall, insert the tongue into the first plank of the first row and drop it until it is lying flat over the underlayment.

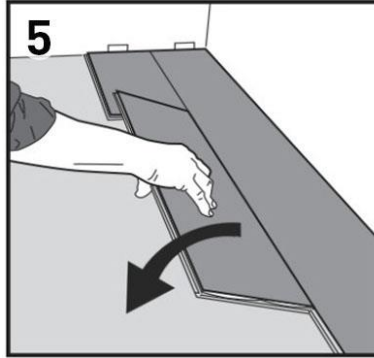

5. For the next plank insert the tongue into the groove of the adjacent plank at a 30° angle, slide it so the short edge is aligned with the previous plank and fold it down. Push the short edge until you hear a clicking sound. Repeat the process with the rest of the planks of the second row. Cut the last plank of the row. Remember to account for the 1/4" expansion gap when doing so.

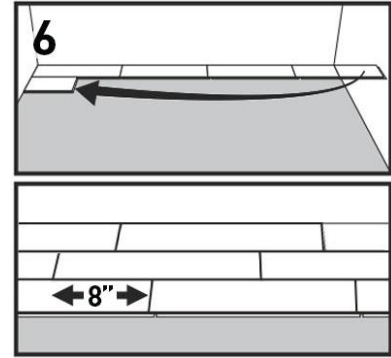

6. Start and complete each row thereafter using the same process. Always make sure that the end joints from adjacent rows are off-set by at least 8 inches. Plan the layout to avoid using small planks (less than 8 inches) at either end of the rows. The cut piece at the end of each row can often be used to start the next row, provided it achieves a random staggered layout.

SPECIAL INSTRUCTIONS

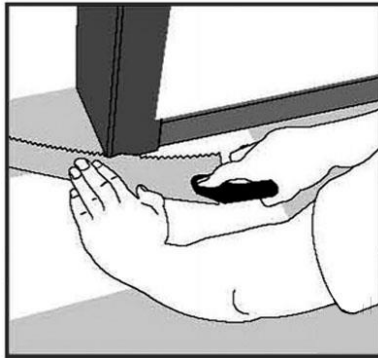

Doors: When fitting planks around door trim it's necessary to slide the plank under the trim. To secure the right cut, turn a plank upside down and place it on the floor up to the door frame. Then place a handsaw flat against the plank and simply cut through the frame. Remove the cut out and vacuum away debris.

You can now secure the plank on the long side next to the door jamb. On tight spaces use an installation pull bar to securely join the long and short joints. Use a series of light taps until the joint is gradually locked together.

Bathrooms: When the vinyl planks are installed in a bathroom, the flooring can be laid under the toilet only if the floor is separated from adjacent rooms with a doorway threshold or transition piece. Otherwise the flooring should be installed around the toilet leaving a 1/8" expansion space. Use a high-quality silicone caulking to fill the expansion space at the tub, shower and all wet areas to prevent surface water seepage under the floor.

Stairs: FORTEM Engineered Waterproof Floors can be installed on stairs using our special NoseTrim molding. It is recommended that the planks be glued-down, to prevent movement. Please visit www.fortem.us/installation or www.installationadvise.com for the complete NoseTrim molding installation instructions.

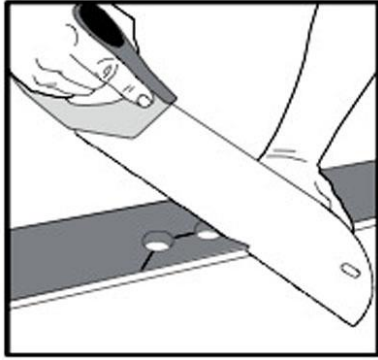

Install around radiator pipes by drilling holes in a plank around 3/4" larger than the diameter of the pipes. Cut out the plank (with the thinnest blade possible) as per the image above. Install the plank as per normal. Glue the cut-out piece back again.

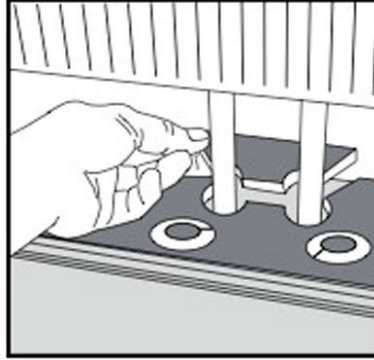

Glue the cut-out piece to the plank itself only. Do not glue it to the underlayment or sub-floor. You must always allow the floor planks to move in all directions after the installation is complete.



Our Waterproof Floors can be easily disassembled to replace planks during installation and in case of damage. Separate the whole row by carefully lifting up and slightly knocking just above the joint. Disassemble the planks by sliding horizontally only.

FINISHING THE INSTALLATION

1. Install transition moldings where needed. Our Engineered Waterproof Floors allow for installations of large areas (up to 4000 sq ft) without the need of expansion gaps from transition moldings (Expansion gaps around the perimeter of the floor are still necessary).
2. Use our SlimTrim when transitioning between two hard surfaces. The SlimTrim molding allows for transitions between floors that are at the same level or at different levels. Use our SlimCap molding when finishing the floor against a sliding door, carpet or a wall without baseboard molding (eg. A rough brick or stacked stone wall). Fasten transition moldings only to the subfloor. **DO NOT** fasten transition moldings to the flooring planks. To learn more be sure to follow the instruction guidelines referring to each transition molding at www.fortem.us/installation or visit www.installationadvice.com for step-by-step installation videos.
3. Install baseboards or quarter round moldings around the perimeter of the floor. Remove the 1/4" spacers before installing. Ensure that the baseboard molding or quarter round is thick enough to cover the expansion gap. Fasten the baseboard or quarter round molding only to the wall. **DO NOT** fasten the baseboard or quarter round molding to the flooring planks.
4. Furniture should be moved onto the newly installed floor using an appliance hand truck over hardboard runways. These floors have an indentation rating of 900 psi (lbs per sq in). It is recommended you use felt-protectors on all furniture legs. **IMPORTANT** It is highly recommended the use of coasters (rigid protectors) that are at least 1" in diameter under heavy furniture legs (eg. bed, sofa, etc.)
5. Post installation temperature must be maintained between 60°F and 85°F. Relative humidity must be maintained between 40% and 70%.

MAINTENANCE

After installing the floor, we recommend a first cleaning to remove any loose dirt or debris that may have been introduced during the installation process. Be careful during this step. Gently sweep the floor before moping.

1. Regularly sweep and vacuum your floors. Dust acts as an abrasive. Keeping your floors dust-free will prolong the life of your finish and wear-layer. Use walk-off mats at outside entrances to reduce the amount of dirt brought into your home.
2. Use a vacuum cleaner suitable for hard surface flooring (with no moving parts or without rotary beater bars) to clean your FORTEM Engineered Waterproof Floors. These floors can also be cleaned with a damp or wet mop. Never use a steam cleaner on your FORTEM Floors.
3. While most non-residue cleaners can be used on your FORTEM Engineered Waterproof Floors, it is always recommended to conduct a small test patch in an inconspicuous area, and avoid using harsh cleaners or ammonia based cleaning products. Always clean your floors with a specialized floor cleaning product like Bona Hardwood Floor Cleaner.
4. Remove spills and other stain-inducing liquids, like pet urine or vomit, from the floor as soon as possible.
5. Avoid exposure to long periods of direct sunlight. If possible, close blinds or drapes during peak sunlight hours. Floor covering subjected to excessive heat and light is subject to thermal degradation. Some natural ventilation or intermittent air conditioning in vacant homes should be considered. Long term continuous inside temperatures over 95°F combined with strong direct sunlight will damage the flooring and cause the installation to fail. Use appropriate precautions to minimize potential effects on the floor covering.
6. Use plastic mats or other protectors under rolling chairs and other types of movable furniture. Excessive abrasion from moving furniture is not considered normal use and is not covered under either of our Limited Residential or Commercial warranties. Use non-staining mats. Rubber may discolor or stain the floor planks.
7. Do not apply polishing compounds or other types of finishing products like wax or “mop and shine” products. **IMPORTANT:** The finish of these floors cannot be made glossier or shinier with ANY product. The surface of your floor is very dense and nonporous, which prevents wax from penetrating and thus builds up a bed for yellowing and dirt collection. These products will damage the factory finish of your floors and void your warranty.
8. Do not allow cigarettes, matches or other hot items to be in contact with the floor as this will cause permanent damage.

In the eventuality that your floors are exposed to excessive amounts of water due to flooding or leaks, do not panic, FORTEM Engineered Waterproof Floors will not get damaged with water. Simply remove the water as quickly as possible using a water pump, fans and a dehumidifier. A dehumidifier should be promptly turned on in the room to reduce the moisture levels back to normal. Do not dry the room below the normal moisture level that existed previously.

Carefully disassemble the planks in the affected area, clean and dry all the flooring planks individually, replace the underlayment and dry the sub-floor. Put all the planks back together following the instructions above.